



AIR LIFT

INSTRUCTIONS • PARTS DRAWING • PARTS LIST

Part Numbers 10740 - 16749 - 16600

WARNING: READ INSTRUCTIONS BEFORE OPERATING

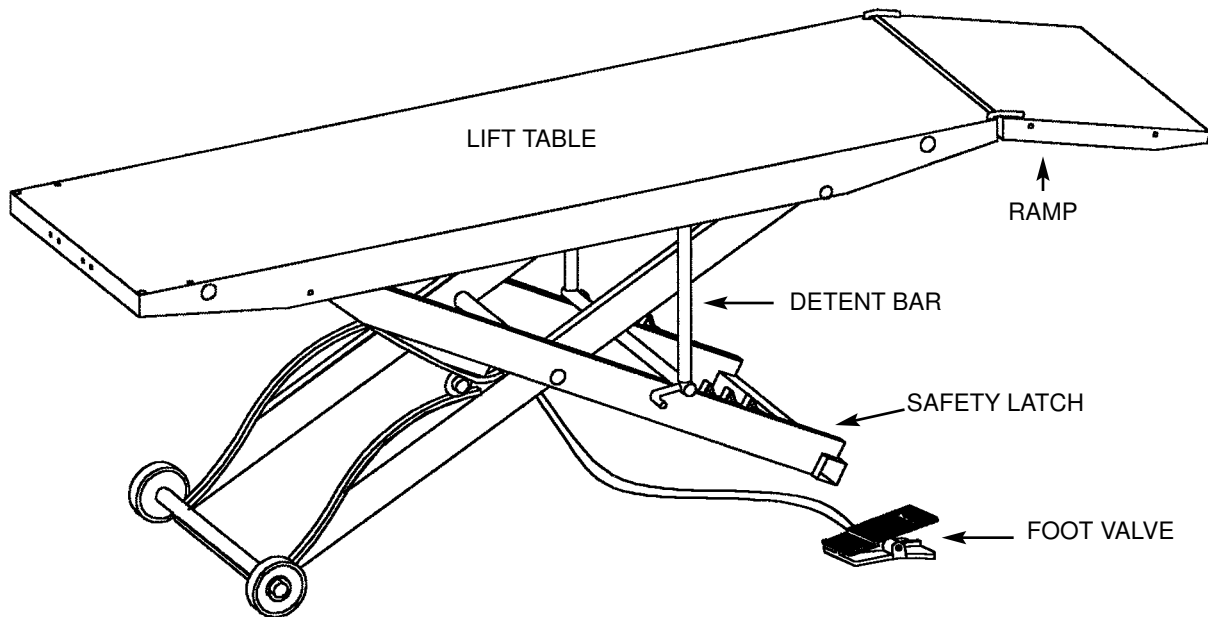

1. Center load on table - 1000 lb. maximum.
2. Connect to 100 psi maximum shop air.
3. Keep safety bar in position at all times - except when lowering.
4. Keep hands and tools from under carriage.
5. Do not mount table when in elevated position.
6. Do not ride vehicle onto lift.
7. Lift must be in the lowered position when moving.
8. Only trained persons should operate Air Lift.
9. The working area should be sufficiently lit.
10. Foot controller should be at least 3 feet away from Air Lift during raising and lowering operation.
11. Recommended for indoor use only.



AIR LIFT



NOTE: READ ENTIRE MANUAL TO COMPLY WITH ALL SAFETY AND SERVICE PRECAUTIONS. DEATH, PERSONAL INJURY AND/OR PROPERTY DAMAGE MAY OCCUR UNLESS INSTRUCTIONS ARE FOLLOWED CAREFULLY.

INSTRUCTIONS

UNPACKING AND SET-UP



1. Open carton, then remove ramp, and shipping boards.
2. **CAREFULLY TURN TABLE UPRIGHT INTO OPERATING POSITION BEFORE REMOVING SHIPPING CABLE RESTRAINT FROM SCISSOR MECHANISM.**



3. Connect foot-operated air valve to 100 psi air supply. The lift may be damaged and/or personal injury may result if the pressure exceeds the maximum 100 psi rating.
 4. Stand clear of lift table and depress the UP side of foot valve to raise table.
 5. To lower table, lift detent bar from safety latch and lower to next position or to floor.
 6. Insert ramp mounting pins into holes at either end of table to mount ramp.
- NOTE:** If cycle vise is being installed, ramp must be mounted opposite the cycle vise.

OPERATION



1. Loads must be centered on table at all times.
2. Loads must be firmly positioned and secured on table at all times.
3. All moving parts have been lubricated at the factory and should be re-lubricated every 6 months to prevent galling. Grease zerks are located at each end of frame pivot shaft and at top ends of inside frame assembly.
4. Lightly oil cylinder rod when it becomes dry.
5. Squirt some oil through air bleed hole in plate end of cylinder to lubricate piston and its seal every 6 months.
6. Pivot shaft set screws should be checked frequently to be sure they are tight. These are located at the top end of the inside frame assembly.

OTHER OPTIONS AVAILABLE

Separate installation instructions included with each option.

PART #	DESCRIPTION
14476	CV-17 CYCLE VISE - Vise with removable wheel stop built into vise
10730	8" SIDE EXTENSIONS (2) - Expands width of lift from 24" to 40"
10728	12" SIDE EXTENSIONS (2) - Expands width of lift from 24" to 48" includes stabilizer bar
16011	13" FRONT EXTENSIONS - Extends lift top to 93" for longer wheel base motorcycles
15566	RAMP END EXTENSION - Attaches to end of lift ramp for a more gradual incline to prevent bigger bikes from dragging bottom.
10737	SNOWMOBILE WING KIT - Used when lifting snowmobiles
14169	TRIKE EXTENSION - Used for 3 wheeled vehicles
16355	CE FOOT PEDAL - Covered foot pedal
10732	LIFT DOLLY - Helps move lift while in down position
15833	RED HANDY TIE-DOWNS - 1 pair - Secure your equipment on our lift with 1" x 6' straps
16010	TOOL TRAY - Keeps tools organized and Handy



REPLACEMENT PARTS

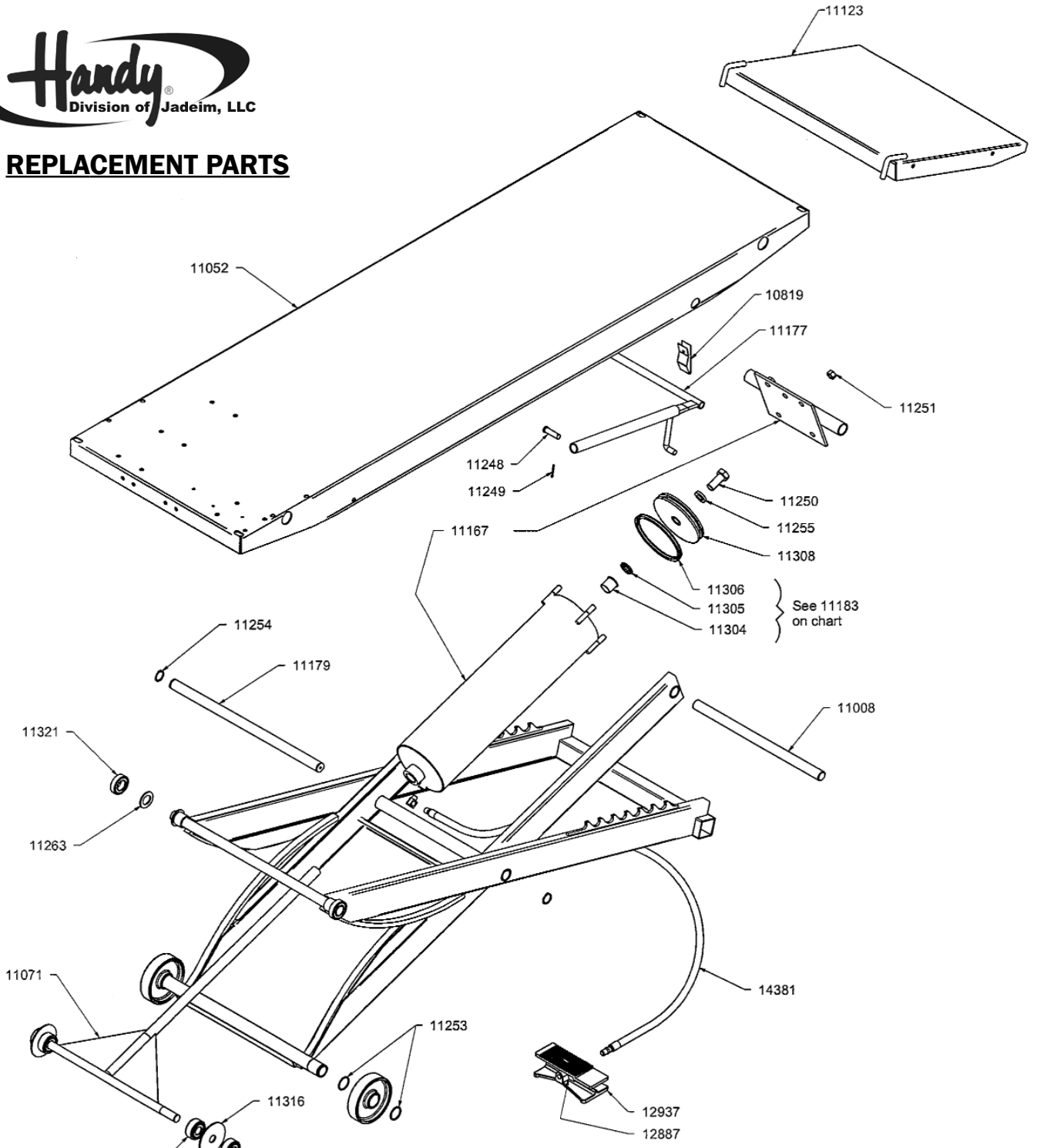

PART NO.	DESCRIPTION	QTY./UNIT
10819	Detent Clip	1
11008	Frame/Cylinder Pivot Shaft	1
11052	Top Assembly	1
11167	Cylinder Assy & End Plate (Gray)	1
11071	Cylinder Shaft Assembly (Gray)	1
14381	Valve Hose w/fittings	1
11123	Ramp Assembly (Gray)	1
12937	Foot Valve Assembly (complete)	1
12887	Valve Stem Assembly	1
11177	Detent Bar	1
11179	Frame Pivot Shaft	1
11183	Cylinder Repair Kit	1
11248	1/2 x 1 3/4 Clevis Pin	2
11249	1/8 x 7/8 Cotter Pin	2

PART NO.	DESCRIPTION	QTY./UNIT
11250	Screw 3/4-10 x 1 3/4	1
11251	1/2 -13 Hex Nut	4
11252	Cam Bearing Retaining Ring	2
11253	Wheel Retaining Ring	4
11254	Frame Shaft Retaining Ring	2
11255	Lock washer - 3/4"	1
11304	Cylinder Shaft Bushing	1
11305	Cylinder Shaft Seal	1
11306	Piston Seal	1
11308	Piston	1
11315	Cam Roller Bearing	4
11316	Cam Bearing Spacer	2
11319	Cast Wheel	2
11321	Track Roller Bearing	2

HANDY LIMITED WARRANTY

Handy Industries Division of Jadeim LLC, warrants to the original purchaser of this product, all parts to be free from defects in manufacture for a period of one (1) year from date of delivery. Notice of a defective part must be received in writing at Handy Industries within one (1) year of purchase. All defective parts must be returned to Handy Industries and which, upon our examination any parts which are defective in manufacture or workmanship, will be replaced or put in good operating condition. This warranty does not apply to damage resulting from accident, improper installation, repair, operation or maintenance, negligence or neglect. THE COST OF SUCH REPLACEMENT OR REPAIR SHALL BE EXCLUSIVE REMEDY FOR ANY BREACH OF ANY WARRANTY AND HANDY INDUSTRIES SHALL NOT BE LIABLE TO ANY PERSON FOR CONSEQUENTIAL DAMAGE, OR INJURY, OR COMMERCIAL LOSS RESULTING FROM ANY BREACH OF WARRANTY. HANDY INDUSTRIES MAKES NO WARRANTY OR MERCHANTABILITY, MAKES NO WARRANTY OF FITNESS FOR A PARTICULAR PURPOSE AND MAKES NO OTHER WARRANTY EXPRESSED OR IMPLIED, INCLUDING IMPLIED WARRANTY ARISING FROM THE COURSE OR DEALING OR USAGE OF THE TRADE.