

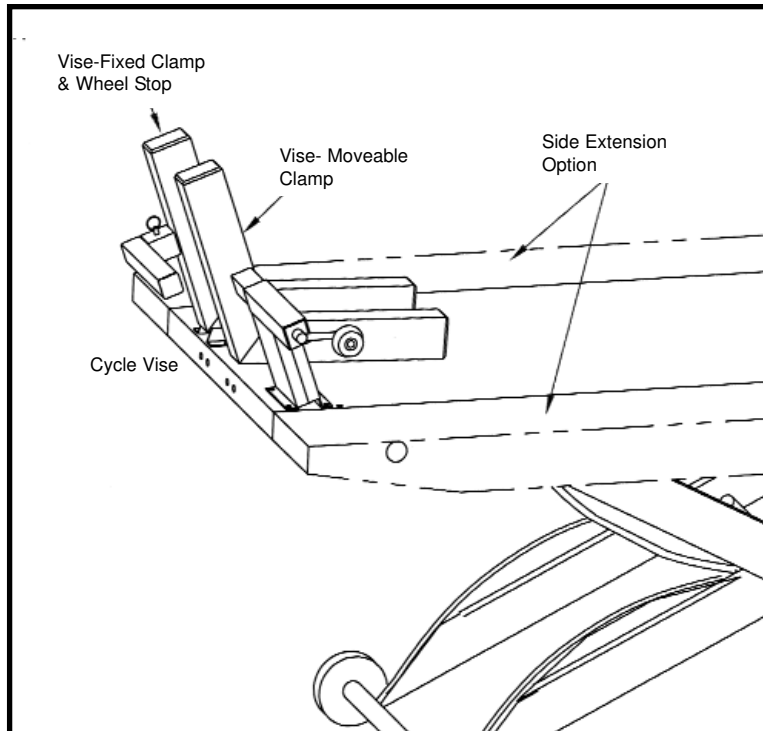

CV-17 CYCLE VISE

ITEM # 14476 - 16588
INSTALLATION INSTRUCTIONS

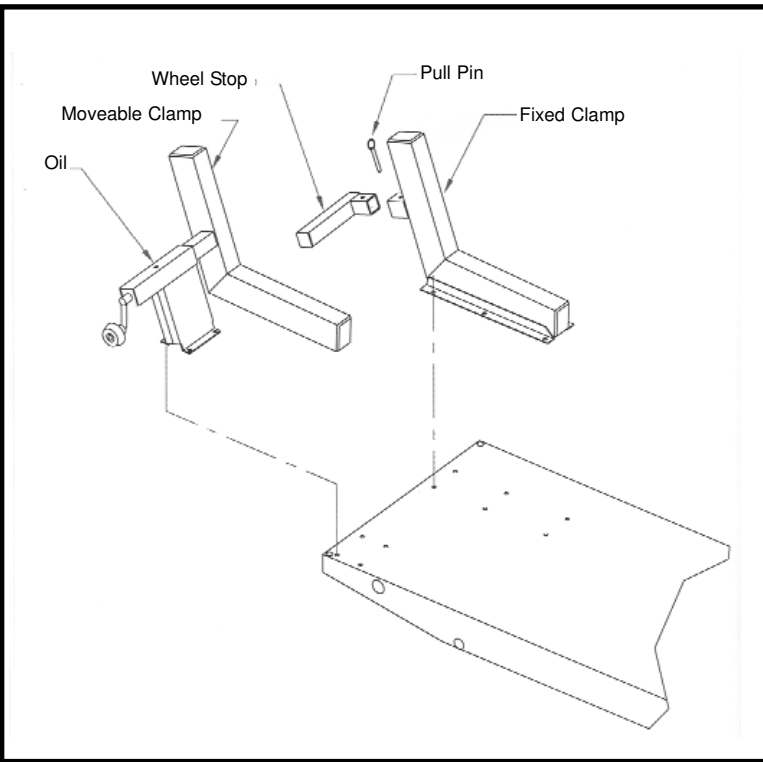

The CV-17 Cycle Vise mounts directly onto most Handy Lifts bought after January 1, 1994. This includes the Air Lift, Electric Lift, the B.O.B 1500 Airlift and the 1650 Hydraulic Lift. The B.O.B 1500 Airlift has (2) sets of mounting holes so that the position of the vise along the length of the table can be changed.

The previous version of the Cycle Vise, CV-16 included a separate wheel or safety stop that bolted to the end of the lift. The safety stop is now a part of the fixed clamp side of the vise as shown. Old safety stops can be purchased from Handy. The CV-16 Cycle Vise will work on the B.O.B 1500 Airlift; however, the safety stop cannot be adjusted along the length of the table.

To install the vise, simply mount the vise as shown with the hardware provided.

Note: The 1650 Hydraulic Lift has two locations for the Cycle Vise. One set on top & one set on the drop leaf.

HANDY DIVISION OF JADEIM, LLC

401 South 2nd. Ave. Marshalltown, IA 50158
Ph 855-752-5446 Fax 641-752-1205 www.handyindustries.com