



# LOUVERED TAILGATES

## CENTER LATCH • STRAIGHT REMOVAL/INSTALLATION INSTRUCTIONS

### CENTER LATCH (CL) - STRAIGHT MODELS (ST)

#### STANDARD TAILGATE REMOVAL

##### MODELS (2510, ST2310) - (CL2519, ST2319) - (CL2531, ST2331) - CL2533, ST2333)

Partially open tailgate. Disconnect the retaining cables from each side of the truck. Tip to align the right pivot tube with mating peg on truck. For models (CL2519, ST2319) see special instructions below. Lift right side off then pull tailgate from left peg and set tailgate aside. Remove the cables from the standard tailgate. On models (CL2510, ST2310) - (CL2531, ST2331) re-install the cable mounting bolts to the standard tailgate. On the (CL2519, ST2319) - (CL2533, ST2333) keep the mounting bolts with the cables.

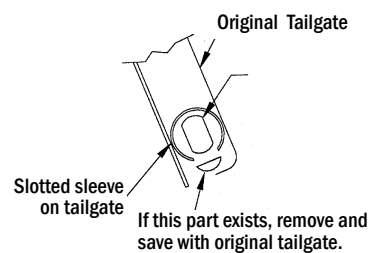
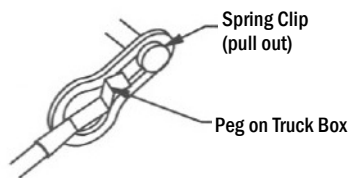

##### MODELS (CL 2519, ST2319) SPECIAL INSTRUCTIONS

A retainer clip may need to be loosened above the right pivot tube on the truck in order for the standard tailgate to be removed. Re-tighten this retainer after the new tailgate has been installed.

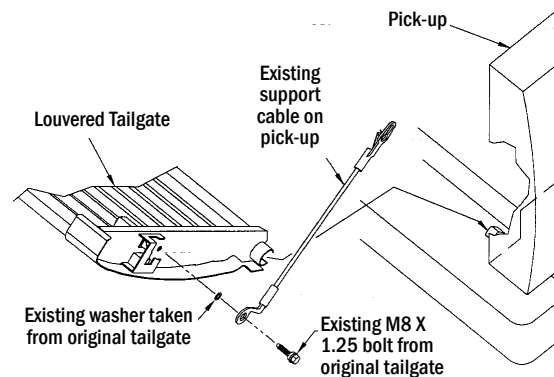
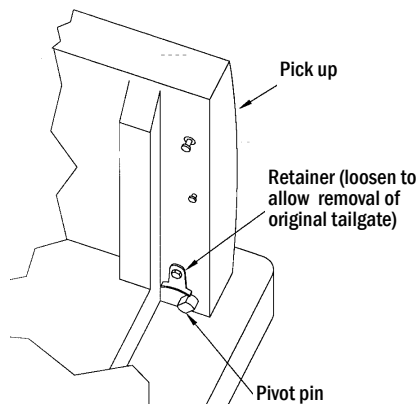

#### **NOTE:**

All Handy Tailgates are shipped with neoprene backing discs in the pivot tubes. Care should be exercised to see that these discs stay in place in order to keep the tailgate centered.

##### MODELS (CL2533, ST2333)

Remove the bushings from both the left and the right pivots of the standard tailgate and install them into the pivot tubes of the new Handy tailgate. Note: There are six neoprene discs installed in each pivot tube of the new tailgate. Use as many of these as possible behind the bushing inserts to center the tailgate and obtain a tight fit. Refer to illustration.

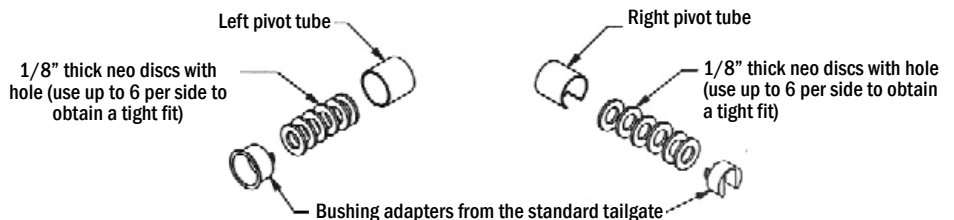

Also, note that additional pivot tube brackets have been sent along loose with your tailgate. If you have an older Dodge model and find that there is too much side to side movement of the new tailgate, bolt these longer pivot tube brackets on in place of the pivot tube brackets now on the Handy tailgate.

**CAUTION!** Failing to transfer the bushing inserts from the pivots of the truck's standard tailgate to the pivots of the new tailgate could result in property damage or personal injury!

### **MODELS (CL2510, ST2310) - (CL2519, ST2319) - (CL2531, ST2331) - (CL2533, ST2333)**

Install the retaining cables to the new Handy tailgate.

On the (CL2510, ST2310) - (CL2531, ST2331) use the bolts supplied with the new tailgate.

On the (CL2519, ST2319) - (CL2533, ST2333) use the bolts still attached to the standard cable.

### **MODELS (CL2520, ST2320)**

**Support Arm Removal (Keyhole Slot):** Partially open the tailgate and push the truck end of the arm (which has the keyhole slot) forward until hole in slot aligns with head of peg on truck, then disconnect arm. These arms will remain with the original tailgate. They are replaced with the cable type support on the Handy louvered tailgate. After installation of the louvered tailgate, simply hook cable loops over the peg on the truck box.

**Tailgate Removal:** Once the arms have been disconnected from the pegs on the truck box the standard tailgate can be removed. Tip tailgate partially open until the slot on the right tailgate pivot tube aligns with the pivot post of the truck box. Lift tailgate off the right pivot post then pull left side off left pivot post. Note: Before installing the louvered remove the plastic insert from the right side peg on the truck box and save it with the standard tailgate. Reverse the procedure to install the louvered tailgate. Be careful not to lose any of the neoprene pads placed in each pivot tube as you install the new louvered tailgate.

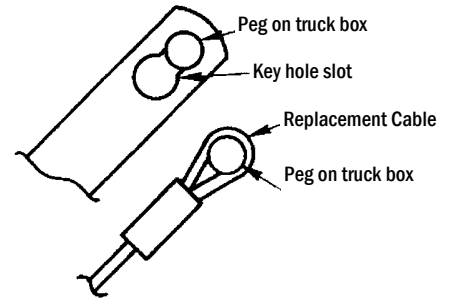

**ADJUSTMENTS** - Because of variances in manufacturer tooling, tailgates may fit differently when installed. Therefore, the following tailgates may be adjusted to fit properly by using these procedures.

### **MODEL CL2510, CL2520, CL2531, CL2533, ST2310, ST2320, ST2331, ST2333**

The pivot bracket adjustments should allow sufficient adjustment for any variances by the truck manufacturer. However, if an acceptable fit cannot be attained with this adjustment, it will be necessary to make further corrections by loosening and adjusting the pivot posts and latch catches on the truck box.

If a vertical adjustment is necessary for the tailgate to match the truck box sides vertically, it may be adjusted by loosening the bolts which secure that pivot bracket to the tailgate and moving that the bracket up or down to achieve an acceptable fit. After a good fit is obtained, be sure all bolts are tightened.

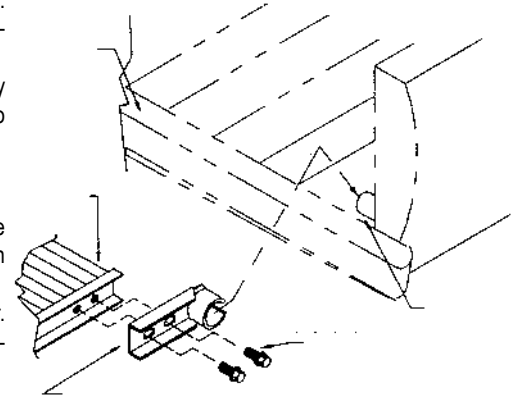

### **MODEL CL2510, CL2310**

These tailgates re equipped with an adjustable stop which is located near the top of the tailgate. If the tailgate does not fit snugly after installation, this stop would be adjusted by loosening its securing bolts and sliding it in or out to achieve the proper fit. After a good fit is obtained, be sure all bolts are tightened.

The pivot bracket adjustments should allow sufficient adjustment for any variances by the truck manufacturer. However, if an acceptable fit cannot be attained with this adjustment, it will be necessary to make further corrections by loosening and adjusting the pivot posts and latch catches on the truck box.

### **MODEL CL2519, ST2319**

The CL251, ST2319 do not have an adjustable pivot bracket. If an acceptable fit cannot be obtained, it maybe necessary to loosen the pivot posts and latch catches on the truck box. If this needs to be done, be sure to retighten all truck components securely after any adjustment have been made.

### **LATCHING MECHANISM**

The **STRAIGHT TAILGATE** latches are engaged and released by pulling on the cable located between the louvers.

The **FIFTH WHEEL TAILGATE** with center handle release is engaged and released by pulling/rotating the release handle out and to the right.

### **CAUTION: TO AVOID INJURY**

When opening tailgate, support tailgate with one hand while using the other hand to move center handle to the release position. **NOTE:** When closing the tailgate, it is advisable to use the release handle to retract the latch pins away from the mating latch or peg for a smoother engaging action.

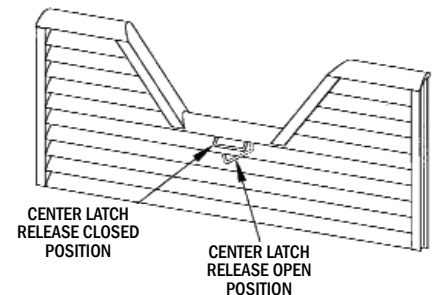

### **HANDY LIMITED WARRANTY**

Handy Industries Division of Jadeim LLC, warrants to the original purchaser of this product, all parts to be free from defects in manufacture for a period of one (1) year from date of delivery. Notice of a defective part must be received in writing at Handy Industries within one (1) year of purchase. All defective parts must be returned to Handy Industries and which, upon our examination any parts which are defective in manufacture or workmanship, will be replaced or put in good operating condition. This warranty does not apply to damage resulting from accident, improper installation, repair, operation or maintenance, negligence or neglect. THE COST OF SUCH REPLACEMENT OR REPAIR SHALL BE EXCLUSIVE REMEDY FOR ANY BREACH OF ANY WARRANTY AND HANDY INDUSTRIES SHALL NOT BE LIABLE TO ANY PERSON FOR CONSEQUENTIAL DAMAGE, OR INJURY, OR COMMERCIAL LOSS RESULTING FROM ANY BREACH OF WARRANTY. HANDY INDUSTRIES MAKES NO WARRANTY OR MERCHANTABILITY, MAKES NO WARRANTY OF FITNESS FOR A PARTICULAR PURPOSE AND MAKES NO OTHER WARRANTY EXPRESSED OR IMPLIED, INCLUDING IMPLIED WARRANTY ARISING FROM THE COURSE OR DEALING OR USAGE OF THE TRADE.



**HANDY INDUSTRIES  
DIVISION OF JADEIM, LLC**

401 South 2nd. Ave. Marshalltown, IA 50158  
Ph 855-752-5446 Fax 641-752-1205  
www.handyindustries.com