



B.O.B. 1500 - AIR LIFT

INSTRUCTIONS - PARTS DRAWING - PARTS LIST

PART NUMBERS: 14472 - 16759 - 17008

WARNING: READ INSTRUCTIONS BEFORE OPERATING

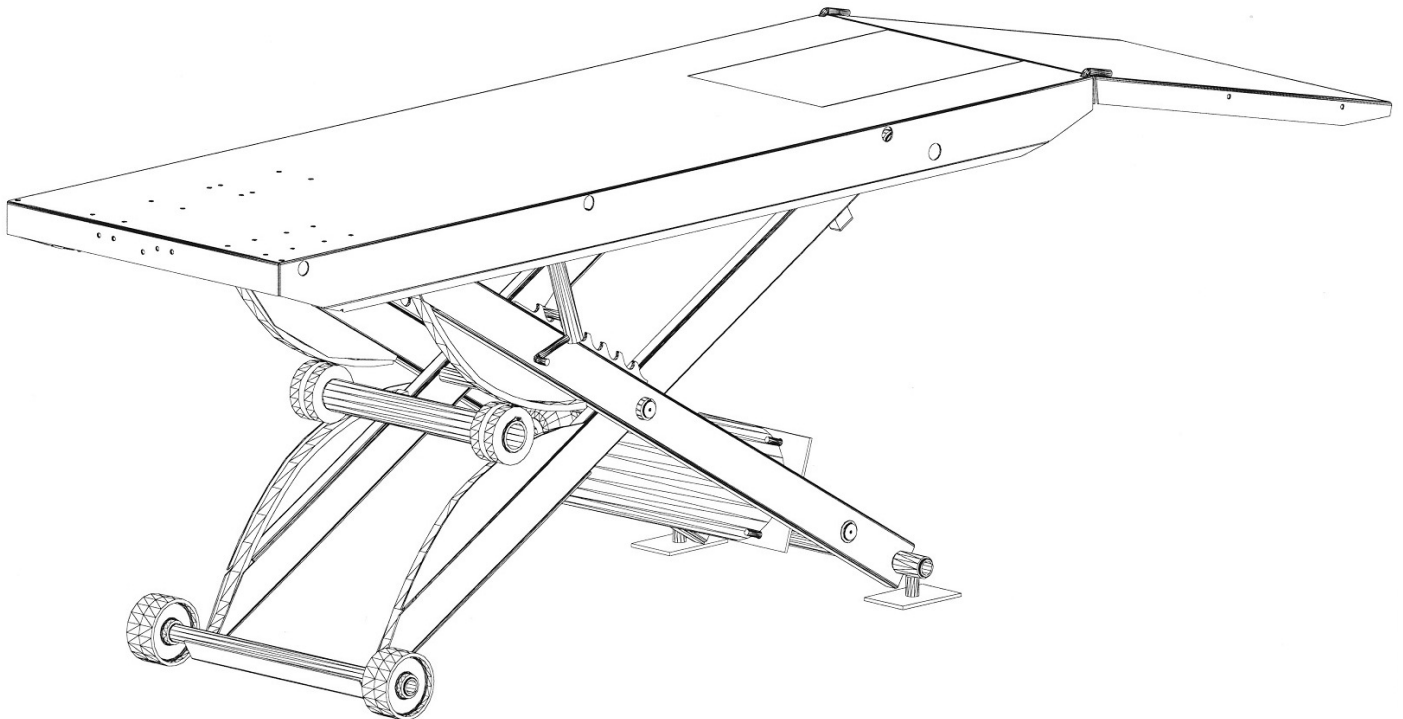

- 1. Center load on table - 1500 lb. maximum.**
- 2. Connect to 100 psi maximum shop air.**
- 3. Keep safety bar in position at all times - except when lowering.**
- 4. Keep hands and tools from under carriage.**
- 5. Do not mount table when in elevated position.**
- 6. Do not ride vehicle onto lift.**
- 7. Lift must be in the lowered position when moving.**
- 8. Only trained persons should operate Air Lift.**
- 9. The working area should be sufficiently lit.**
- 10. Foot controller should be at least 3 feet away from Air Lift during raising and lowering operation.**

B.O.B. 1500 - AIR LIFT



NOTE: READ ENTIRE MANUAL TO COMPLY WITH ALL SAFETY AND SERVICE PRE-CAUTIONS. DEATH, PERSONAL INJURY AND/OR PROPERTY DAMAGE MAY OCCUR UNLESS INSTRUCTIONS ARE FOLLOWED CAREFULLY.

INSTRUCTIONS

UNPACKING AND SET-UP

1. Open carton, then remove ramp and shipping boards.
- ▲ 2. Connect foot-operated air valve to 100 psi maximum air supply. The lift may be damaged and/or personal injury may result if the pressure exceeds the maximum 100 psi rating.
3. Stand clear of lift table, and depress the UP side of foot valve to raise table.
4. To lower table, lift detent bar from safety latch and lower to next position or to floor.
5. To mount ramp, insert ramp mounting pins into holes at end of table opposite vise holes.

OPERATION

- ▲ 1. Loads must be centered on table at all times. Table is rated for a maximum load of 1500 lbs.
- ▲ 2. Loads must be firmly positioned and secured on table at all times.
3. All moving parts have been lubricated at the factory and should be re-lubricated every (6) months to prevent galling. Grease zerks are located at each end of frame pivot shaft and at top ends of inside frame assembly.
4. Lightly oil cylinder rod when it becomes dry.
5. Squirt some oil through bleed hole in plate end of cylinder to lubricate piston and its seal every (6) months.
6. Pivot shaft set screws should be checked frequently to be sure they are tight. These are located at the top end of the inside frame assembly.

OTHER OPTIONS AVAILABLE

Separate installation instructions included with each option.

PART#	DESCRIPTION
14476	CV-17 CYCLE VISE- Used to stabilize motorcycles while on lift.
14473	12" SIDE EXTENSION (2) - Expands width of lift from 28" to 52" includes stabilizer bar.
14474	13" FRONT EXTENSION - Extends lift top to 97" for longer wheel base motorcycles.
14475	TRIKE EXTENSION - Used for 3 wheeled vehicles.

B.O.B. 1500 - AIR LIFT

PARTS DRAWING - PARTS LIST

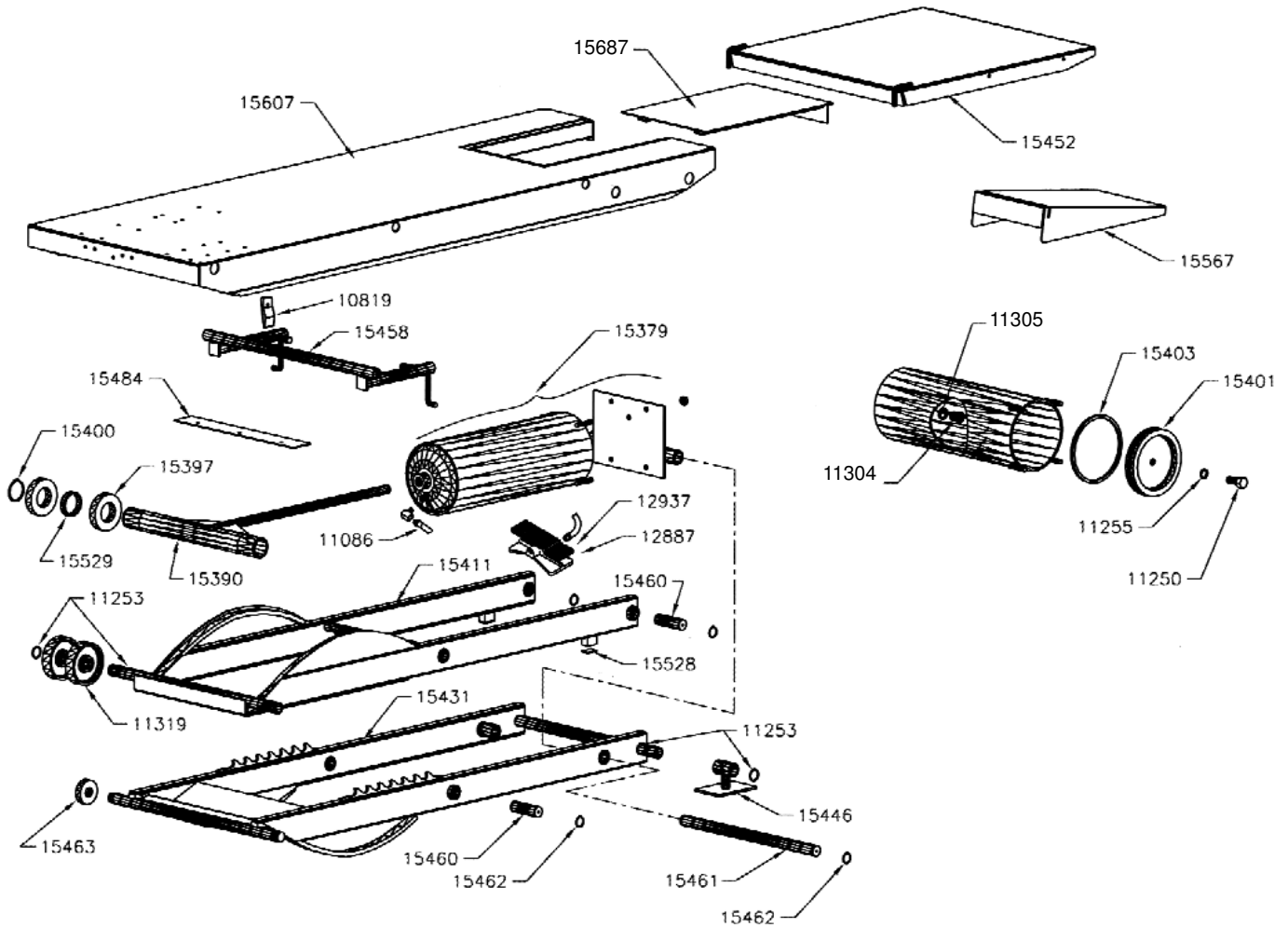

Part #	Description
10819	detent clip
11086	valve hose w/fitting
11250	screw 3/4 -10 x 1-3/4
11253	retaining ring 1-5/16
11255	lockwasher - 3/4"
11319	wheel
12887	valve stem assembly
12937	foot valve assembly complete
11304	cylinder shaft bushing
11305	cylinder shaft seal
15379	cylinder assembly
15390	cylinder shaft assembly
15397	cam roller bearing
15400	retaining ring 2-3/8"
15401	piston
15403	piston seal

Part#	Description
15607	top assembly
15411	inside frame assembly
15431	outside frame assembly
15446	foot assembly
15452	ramp
15687	drop out cover
15458	detent bar
15460	frame pivot shaft
15461	cylinder pivot shaft
15462	retaining ring 1-1/4"
15463	track roller bearing
15484	cover plate
15528	rubber pad
15529	spacer
15567	ramp end extension

HANDY LIMITED WARRANTY

Handy Industries Division of Jadeim LLC, warrants to the original purchaser of this product, all parts to be free from defects in manufacture for a period of one (1) year from date of delivery. Notice of a defective part must be received in writing at Handy Industries within one (1) year of purchase. All defective parts must be returned to Handy Industries and which, upon our examination any parts which are defective in manufacture or workmanship, will be replaced or put in good operating condition. This warranty does not apply to damage resulting from accident, improper installation, repair, operation or maintenance, negligence or neglect. THE COST OF SUCH REPLACEMENT OR REPAIR SHALL BE EXCLUSIVE REMEDY FOR ANY BREACH OF ANY WARRANTY AND HANDY INDUSTRIES SHALL NOT BE LIABLE TO ANY PERSON FOR CONSEQUENTIAL DAMAGE, OR INJURY, OR COMMERCIAL LOSS RESULTING FROM ANY BREACH OF WARRANTY. HANDY INDUSTRIES MAKES NO WARRANTY OR MERCHANTABILITY, MAKES NO WARRANTY OF FITNESS FOR A PARTICULAR PURPOSE AND MAKES NO OTHER WARRANTY EXPRESSED OR IMPLIED, INCLUDING IMPLIED WARRANTY ARISING FROM THE COURSE OR DEALING OR USAGE OF THE TRADE.