

# **CE Foot Pedal Instructions**

**P/N 16355**

The CE Foot Pedal is designed to meet the requirements of European CE standards, specifically Machinery Directive 98/37/EC. Because the actuation pedals are covered, it minimizes the risk of an object falling onto the pedal and actuating the air lift. It also has the feature of automatically stopping the up or down travel of the lift when one of the pedals is released. The pedal fits any Handy Air Lift.

The drawings below show how to connect the pedal to a Handy Air Lift.

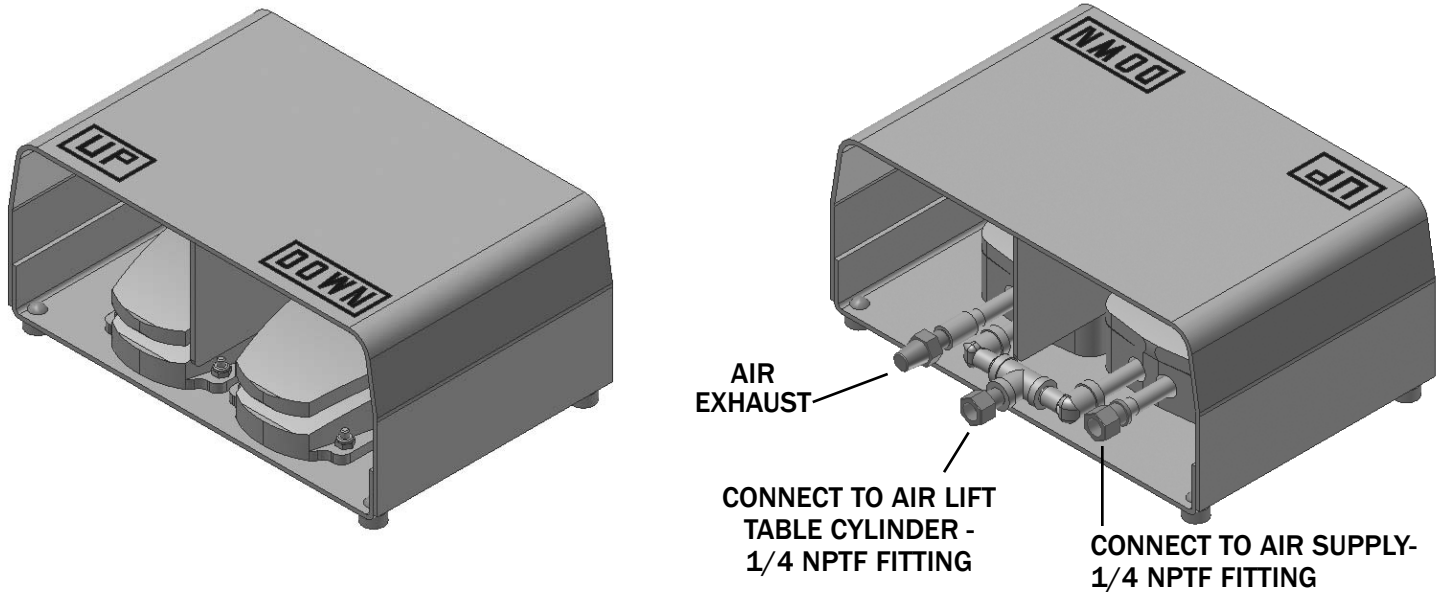

# **CE Foot Pedal Instructions**

**P/N 16355**

The CE Foot Pedal is designed to meet the requirements of European CE standards, specifically Machinery Directive 98/37/EC. Because the actuation pedals are covered, it minimizes the risk of an object falling onto the pedal and actuating the air lift. It also has the feature of automatically stopping the up or down travel of the lift when one of the pedals is released. The pedal fits any Handy Air Lift.

The drawings below show how to connect the pedal to a Handy Air Lift.

